

AWWA Gate Valve with Hand-Wheel, IPS Threaded

Fig. 10NW



Design Features

- 250 lb. non-shock CWP
- Ductile Iron Body and Bonnet
- Stainless Steel Non-Rising Stem
- Wax Encapsulated Cap Screws
- Fusion Bonded Epoxy Coating
- Meets AWWA C515
- Bronze wedge nut

Parts & Materials

No.	Part	Material
1	Body	Ductile Iron Gr. A536 65/45/12
2	Wedge	Ductile Iron Gr. A536 65/45/12; Buna-N
3	Wedge Nut	Bronze B584 C83600
4	Stem	Stainless Steel 304
5	Bonnet	Ductile Iron Gr. A536 65/45/12
6	Packing Gland	Ductile Iron Gr. A536 65/45/12
7	Stem Wiper	Buna-N
8	Hand-Wheel	Ductile Iron Gr. A536 65/45/12
9	Handle Bolt	Stainless Steel 304
10	Bonnet O-Ring	Buna-N
11	Bonnet Bolts	Stainless Steel 304
12	Gasket	Buna-N
13	Packing / Bonnet O-Ring	Buna-N
14	Packing / Gland O-Ring	Buna-N

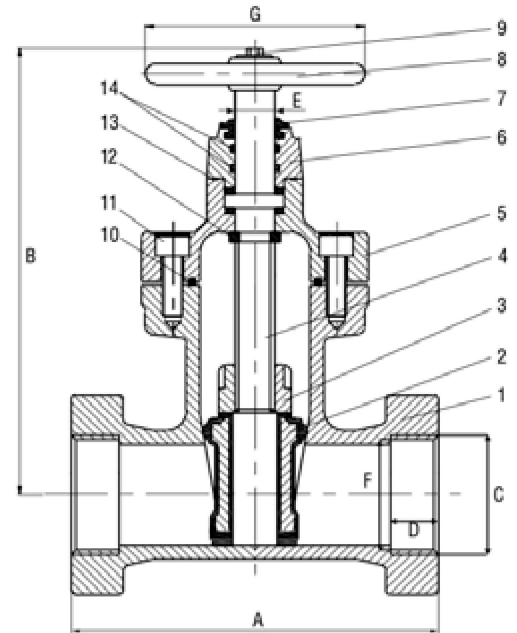

Dimensions

Size	Part Number	Weight	A	B	C	D	E	F	G
In		Lb	In	In	In	In	In	In	In
2	017110NW020	24	7.01	10.31	2.37	0.79	0.79	2.15	7.09
3	017110NW030	49	7.99	11.73	3.50	1.00	0.87	3.22	7.87
4	017110NW040	68	9.02	13.78	4.50	1.09	1.02	4.22	9.84