

## TKD SERIES 3-WAY BALL VALVES - TRUE UNION

The TKD offers a host of advanced features that set it apart from other multi-port valves. The patented seat stop carrier allows for in-line micro-adjustment of the ball seating, and features o-ring cushioning to minimize wear and prevent seizing. Integral mounting flange and bracketing allows for direct actuation and simple support, while a locking handle can prevent improper positioning. The TKD is available in PVC with PTFE seats and either EPDM or Viton® seals. Other materials are available upon request.

Pressure: 232 psi at 73°F

Sizes: 1/2" – 2"



End Connection	Size inches	EPDM Product Code	Viton® Product Code
----------------	-------------	-------------------	---------------------

### PVC, w/ PTFE Seats , L-Port

S/T	1/2	253844	253856
S/T	3/4	253845	253857
S/T	1	253846	253858
S/T	1-1/4	253847	253859
S/T	1-1/2	253848	253860
S/T	2	253849	253861

### PVC, w/ PTFE Seats , T-Port

S/T	1/2	253850	253862
S/T	3/4	253851	253863
S/T	1	253852	253864
S/T	1-1/4	253853	253865
S/T	1-1/2	253854	253866
S/T	2	253855	253867

Ball valves are generally used for on/off service, but can range from simple molded-in-place construction to high-end industrial designs with many features and benefits. Multi-port ball valves allow for mixing, diverting, and bypassing flow. Extensive material options provide for complete chemical compatibility in highly corrosive processes. Many ball valves feature full port flow, blocking true union ends, and compact ergonomic designs allowing for simple installation and maintenance.

# PHYSICAL PROPERTIES

PVC (POLYVINYL CHLORIDE) CPVC (CHLORINATED POLYVINYL CHLORIDE)

PROPERTIES	MATERIALS			STANDARDS
	PVC	CPVC (STANDARD)	CORZAN CPVC (HIGH IMPACT)	
Cell classification	12454	23447	24448	ASTM D1784
Specific gravity	1.42	1.50	1.51	ASTM D792
Tensile strength, psi at 73°F	7,000	7,500	7,320	ASTM D638
Modulus of elasticity tensile, psi at 73°F	400,000	380,000	423,000	ASTM D638
Flexural strength, psi	14,500	11,400	13,200	ASTM D790
Izod impact, ft.lbs./in. at 73°F, notched	0.65	2.0	10.0	ASTM D256
Compressive strength, psi	9,000	10,100	10,100	ASTM D695
Poisson's ratio	0.38	0.33	0.33	
Working stress, psi at 73°F	2,000	2,000	2,000	
Coefficient of thermal expansion in./in./°F (x 10 <sup>-5</sup> )	3.0	3.8	3.4	ASTM D696
Linear expansion, in./10°F per 100' of pipe	0.36	0.44 - 0.46	0.41	
Maximum operating temperature under pressure	140°F (60°C)	200°F (93°C)	200°F (93°C)	
Deflection temperature under load, °F at 66 psi	173	n/a	n/a	ASTM D648
Deflection temperature under load, °F at 264 psi	160	212	239	ASTM D648
Thermal conductivity, BTU.in./hr.ft <sup>2</sup> .°F	1.2	0.95	0.95	ASTM C177
Burning rate	Self extinguish	Self extinguish	Self extinguish	ASTM D635
Burning class	V-0	V-0	V-0	UL-94
Flash ignition, °F	730	900	900	
Limited oxygen index (%)	43	60	60	ASTM D2863-70
Water absorption, %, (24 hrs. at 73°F)	0.05	0.03	0.03	ASTM D570

\* The properties listed in this table represent general material properties and should be used as a guideline only.

**PVC PIPE PRESSURE RATINGS**

Sizes		IPEX schedule 40 PVC			IPEX Schedule 80 PVC		
Diameter	O.D.	Wall Thickness	I.D.	*Max. Pressure 73°F	Wall Thickness	I.D.	*Max. Pressure 73°F
(in.)	(in.)	(in.)	(in.)	(psi)	(in.)	(in.)	(psi)
1/4	.540	–	–	–	.119	.302	1,130
3/8	.675	–	–	–	.126	.423	920
1/2	.840	.109	.602	600	.147	.526	850
3/4	1.050	.113	.804	480	.154	.722	690
1	1.315	.133	1.029	450	.179	.936	630
1-1/4	1.660	.141	1.360	370	.191	1.255	520
1-1/2	1.900	.145	1.590	330	.200	1.476	470
2	2.375	.154	2.047	280	.218	1.913	400
2-1/2	2.875	.203	2.445	300	.276	2.290	420
3	3.500	.216	3.042	260	.300	2.864	370
4	4.500	.237	3.998	220	.337	3.786	320
6	6.625	.280	6.031	180	.432	5.709	280
8	8.625	.322	7.941	160	.500	7.565	250
10	10.750	.365	9.976	140	.593	9.493	230
12	12.750	.406	11.888	130	.687	11.294	230
14	14.000	.438	13.072	130	.750	12.412	220
16	16.000	.500	14.936	130	.843	14.224	220
18	18.000	.562	16.809	130	.937	16.014	220
20	20.000	.593	18.743	120	1.031	17.814	220
24	24.000	.687	22.544	120	1.218	21.418	210

**CPVC PIPE PRESSURE RATINGS**

Sizes		IPEX schedule 40 CPVC			IPEX Schedule 80 CPVC		
Diameter	O.D.	Wall Thickness	I.D.	*Max. Pressure 73°F	Wall Thickness	I.D.	*Max. Pressure 73°F
(in.)	(in.)	(in.)	(in.)	(psi)	(in.)	(in.)	(psi)
1/2	.840	.109	.602	600	.147	.526	850
3/4	1.050	.113	.804	480	.154	.722	690
1	1.315	.133	1.029	450	.179	.936	630
1-1/4	1.660	.141	1.360	370	.191	1.255	520
1-1/2	1.900	.145	1.590	330	.200	1.476	470
2	2.375	.154	2.047	280	.218	1.913	400
2-1/2	2.875	.203	2.445	300	.276	2.290	420
3	3.500	.216	3.042	260	.300	2.864	370
4	4.500	.237	3.998	220	.337	3.786	320
6	6.625	.280	6.031	180	.432	5.709	280
8	8.625	.322	7.941	160	.500	7.565	250
10	10.750	.365	9.976	140	.593	9.493	230
12	12.750	.406	11.888	130	.687	11.294	230
14	14.000	.438	13.072	130	.750	12.412	220
16	16.000	.500	14.936	130	.843	14.224	220

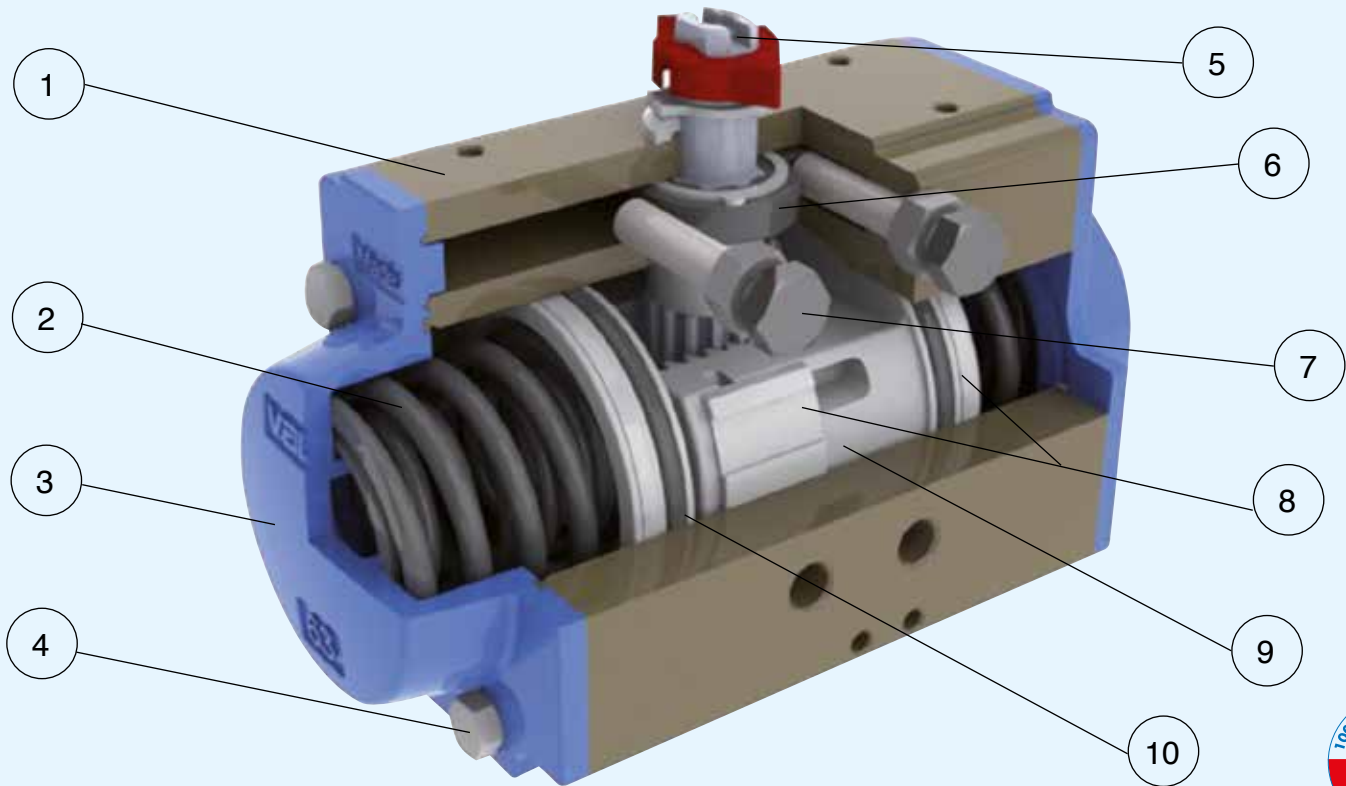

**1 BODY MANUFACTURED FROM EXTRUDED ALUMINIUM UNI 6060:**

- Hard-coat anodized as standard finish 45-50 (micron).
- Good wear resistance.
- High corrosion resistance.
- Special finishes nichel-plating or P.T.F.E coated upon request.
- Bore finished to high standard to ensure low friction and long life.

**2 CONCENTRING SPRING SETS**

- Standard coating painted.
- High resistance and reliability.
- Spring sets to suit different air pressure/torque requirements.
- Long securing screws to allow safe dismantling for maintenance.
- Same body dimensions for DA/SR versions.

**3 DIE CAST ALUMINIUM END CAPS:**

- Standard polyester powder coated
- Upon request nickel - plated and or P.T.F.E coated for corrosive environments.

**4 ASSEMBLING SCREW:**

- Stainless steel as standard.

**EXTERNAL CONNECTION:**

- Top of pinion according to Namur norm.
- Solenoid valve connection according to Namur norm.
- Bottom of pinion according to ISO 5211-DIN 3337.

**NOMINAL VALUES:**

- Pressure rating max 8 bar.
- Temperature range: standard (-4°F;+185°F), high (-4°F;+302°F), low (-40°F;+185°F).
- Pre lubricated for life of actuator on assembly.
- Fully tested on manufacture 100%.

**MOUNTING VARIATIONS**

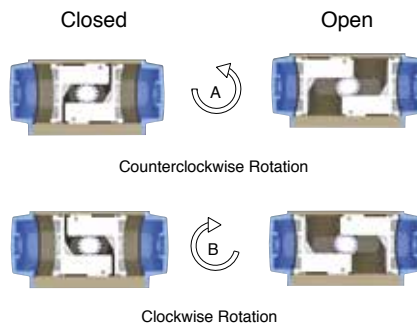

View from the top of the pinion

**ANTI-BLOWOUT SYSTEM**

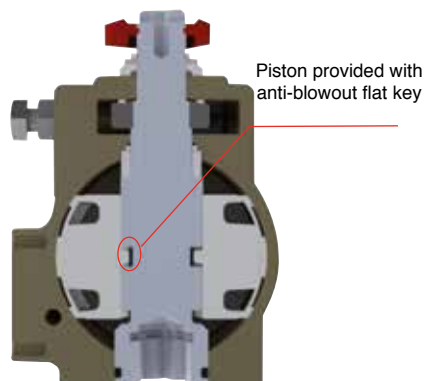

**5 PINION MADE IN STEEL:**

- Nichel-plated for standard version against internal and external corrosion.
- Stainless steel for corrosive environments upon request.
- Anti-blowout design.

**6 CAM FOR LIMIT POSITION ADJUSTMENT 0°-90°:**

- Stainless steel.
- Adjustment for open and close position  $\pm 5^\circ$ .

**7 0-90° ADJUSTMENT SCREWS:**

- Stainless steel.

**8 PISTON GUIDES IN POM:**

- Large contact area.
- Low friction for self lubricating material.
- Long life.

**9 PISTONS MADE FROM DIE CAST ALUMINIUM:**

- Chemical nickel plating upon request.

**10 SEALS:**

- NBR standard version.
- Viton high temperature version.
- Silicon low temperature version.

**TWIN RACK AND PINION DESIGN:**

- Constant torque output.
- Compact design.
- Balanced internal forces.
- Robust design to ensure long life.

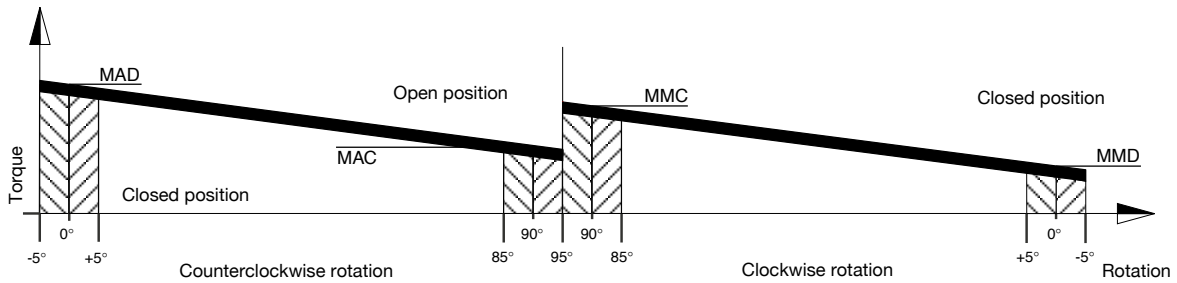
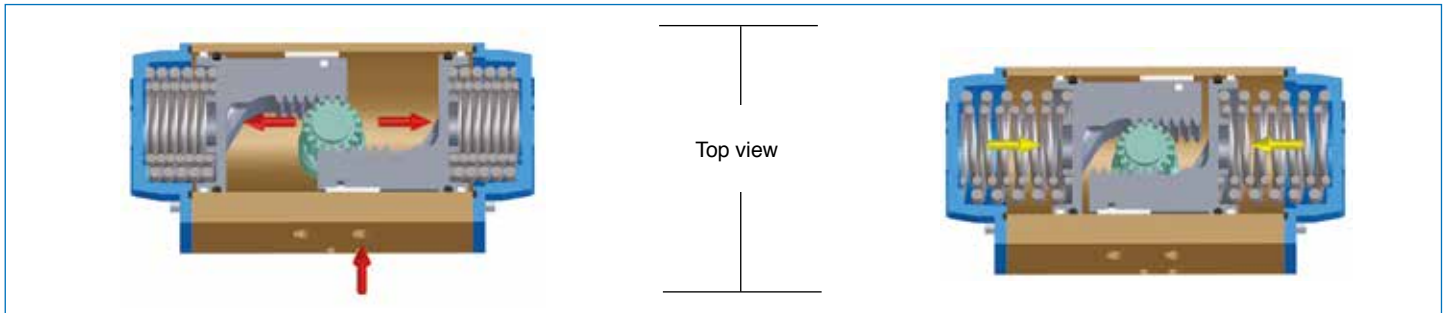

With reference to the above diagram the torque of a spring return actuator is not constant but decreasing. This is due to the action of the springs that when compressed during air actuation counteract the piston movement and accumulate energy which will be available in a decreasing way during the rotation inversion. The torque given by the actuator is defined by four fundamental values.

- Opening rotation
- MAD = Actuator torque with unfolded springs
- MAC = Actuator torque with compressed springs.
- Closing rotation
- MMC = Torque with compressed springs.
- MMD = Torque with unfolded springs

The users can decide on which model to choose according their own specific requirements, using the following guidelines:

1. Define the maximum torque of the valve to automate.
2. To obtain a safety factor increase the torque value chosen by 25% - 50% (subject to the type of valve and working conditions).
3. Once the torque value suggested is obtained consult the torque chart and in relation to the corresponding air pressure find the torque value exact to or exceeding the one obtained, taking account of the lower value between the MMD and MAC values.
4. Once the torque value is determined move horizontally to the column "model" to find the actuator model required.

VALID FROM MOD. 52 TO MOD. 140 \*

**SPRING SETTING**

SET STANDARD 05

SET	EXTERNAL SPRING	INTERNAL SPRING
01	1	1
02	2	-
03	1	2
04	2	1
05	2	2

VALID FROM MOD. 160 TO MOD. 200

**SPRING SETTING**

SET STANDARD 06

SET	EXTERNAL SPRING	CENTRAL SPRING	INTERNAL SPRING
01	-	2	-
02	2	-	-
03	1	2	-
04	2	-	2
05	2	2	-
06	2	2	2

VALID FROM MOD. 230 TO MOD. 330

**SPRING SETTING**

PRETENSIONED SPRING

SET	N° OF SPRINGS FOR EACH SIDE	
01	2/3	
02	3/3	
03	3/4	
04	4/4	
05	4/5	
06	5/5	
07	5/6	
08	6/6	

MOD.230  
MOD.270 e 330

\* Valid also for stainless steel actuator from mod. 52 to mod. 100.

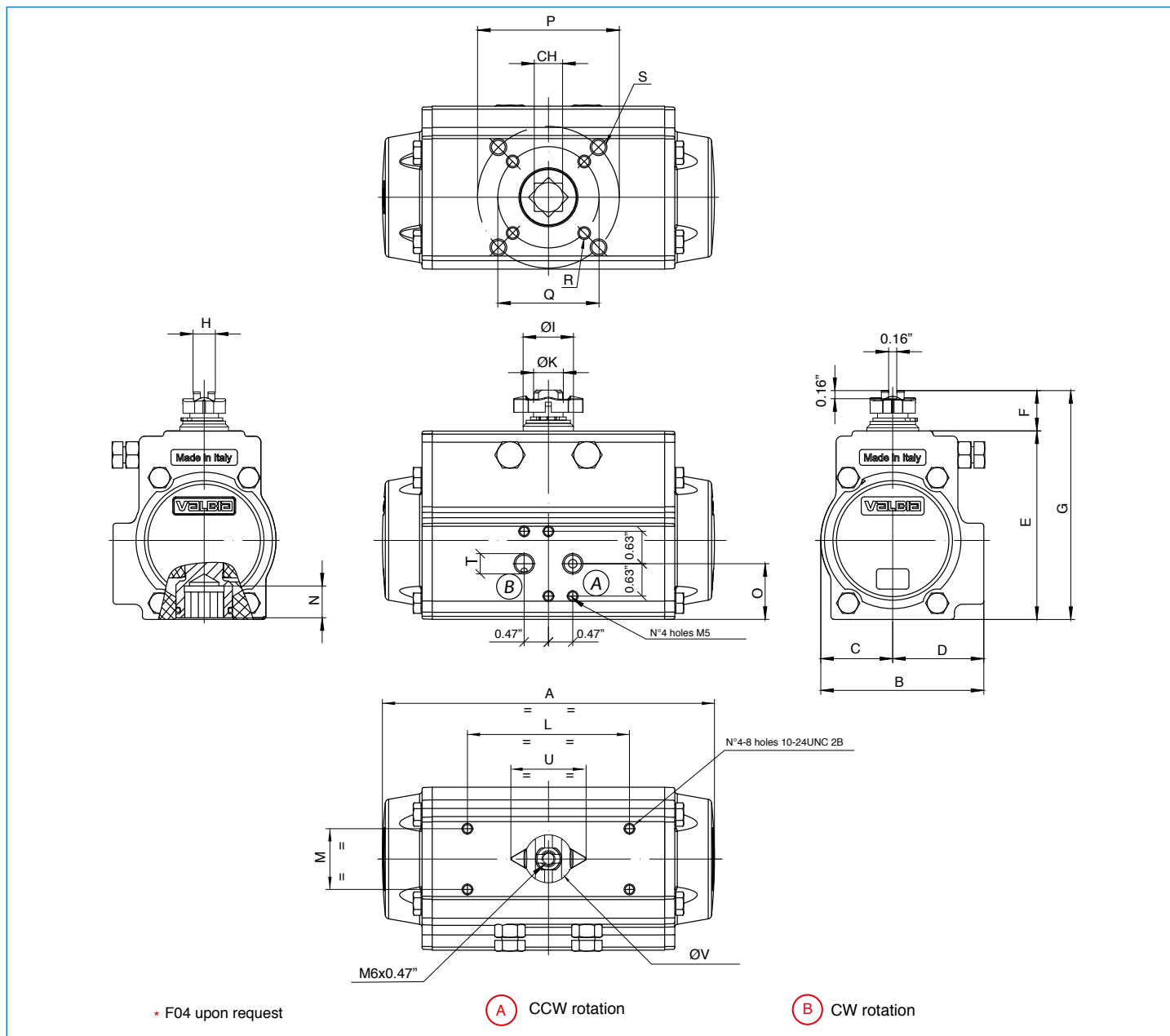

MOD.	DRILLING ISO 5211	CH	A	B	C	D	E	F	G	H	ØI	ØK	L	M	N	O	P	Q	R	S	T NPT	U	øV
52	F03-F05 *	0.43	5.55	2.80	1.18	1.61	3.21	0.79	4.00	0.39	0.83	0.47	3.15	1.18	0.47	1.04	1.97	1.42	10-24 UNC 2Bx0.29"	1/4-20 UNC 2Bx0.35"	1/8"	1.36	0.87
63	F05 - F07	0.55	6.46	3.17	1.40	1.77	3.66	0.79	4.45	0.43	0.98	0.59	3.15	1.18	0.63	1.08	2.76	1.97	1/4-20 UNC 2Bx0.31"	5/16-18 UNC 2Bx0.47"	1/8"	1.36	0.87
75	F05 - F07	0.67	8.27	3.72	1.65	2.07	4.37	0.79	5.16	0.51	1.14	0.75	3.15	1.18	0.75	1.38	2.76	1.97	1/4-20 UNC 2Bx0.31"	5/16-18 UNC 2Bx0.47"	1/8"	1.65	1.14
85	F05 - F07	0.67	9.47	4.17	1.87	2.30	4.92	0.79	5.71	0.59	1.38	0.86	3.15	1.18	0.75	1.65	2.76	1.97	1/4-20 UNC 2Bx0.31"	5/16-18 UNC 2Bx0.47"	1/8"	1.65	1.14
100	F07 - F10	0.67	10.83	4.84	2.17	2.68	5.43	0.79	6.21	0.59	1.38	0.86	3.15	1.18	0.81	1.97	4.02	2.76	5/16-18 UNC 2Bx0.31"	3/8-16 UNC 2Bx0.55"	1/4"	1.65	1.14
115	F07 - F10	0.87	13.11	5.39	2.52	2.87	6.39	1.18	7.57	0.87	1.93	1.26	3.15/5.12	1.18	0.94	1.97	4.02	2.76	5/16-18 UNC 2Bx0.47"	3/8-16 UNC 2Bx0.59"	1/4"	2.52	1.73
125	F07 - F10	0.87	14.65	5.83	2.68	3.15	6.87	1.18	8.05	0.87	1.93	1.26	3.15/5.12	1.18	0.94	2.40	4.02	2.76	5/16-18 UNC 2Bx0.47"	3/8-16 UNC 2Bx0.59"	1/4"	2.52	1.73
140	F10 - F12	1.06	17.13	6.46	3.01	3.44	7.76	1.18	8.94	0.94	1.93	1.38	3.15/5.12	1.18	1.14	2.80	4.92	4.02	3/8-16 UNC 2Bx0.59"	1/2-13 UNC 2Bx0.71"	1/4"	2.52	1.73
160	F10 - F12	1.06	19.69	7.32	3.43	3.90	8.70	1.18	9.88	1.18	2.24	1.57	3.15/5.12	1.18	1.26	3.15	4.92	4.02	3/8-16 UNC 2Bx0.55"	1/2-13 UNC 2Bx0.67"	1/4"	3.17	2.36
180	F10 - F14	1.42	19.41	8.38	3.86	4.53	9.96	1.18	11.14	1.42	2.44	1.77	3.15/5.12	1.18	1.69	3.90	5.51	4.02	3/8-16 UNC 2Bx0.59"	5/8-11 UNC 2Bx0.98"	1/4"	3.17	2.36
200	F14	1.42	22.76	8.54	4.25	4.29	10.94	1.18	12.13	1.42	2.64	1.97	3.15/5.12	1.18	1.46	3.07	5.51	/	/	5/8-11 UNC 2Bx0.94"	1/4"	3.17	2.36
230	F16	* 1.81	27.17	9.78	4.88	4.90	12.80	1.18	13.98	1.42	2.64	1.97	3.15/5.12	1.18	1.97	3.62	6.50	/	/	3/4-10 UNC 2Bx1.14"	1/4"	3.17	2.36

\*\* Only square connection at 45°.

# TORQUE OUTPUT SR ACTUATORS

MOD.	SET	SPRING TORQUE (in-Lbs)		AIR SUPPLY PRESSURE (psi)																
				40		50		60		70		80		90		100		115		
				TORQUE OUTPUT SPRING RETURN ACTUATORS (in-Lbs)																
0° MMD	90° MMC	0° MAD	90° MAC	0° MAD	90° MAC	0° MAD	90° MAC	0° MAD	90° MAC	0° MAD	90° MAC	0° MAD	90° MAC	0° MAD	90° MAC	0° MAD	90° MAC	0° MAD	90° MAC	
SR52 *	1	32	44	48	23	72	47	95	70											
	2	42	59			61	31	84	54	108	77									
	3	46	66					80	47	104	70	127	94	150	117					
	4	57	82					70	31	93	55	116	78	140	101	163	125			
	5	72	105							78	32	101	55	125	78	148	102	183	137	
SR63 *	1	44	85	92	38	134	80	176	122											
	2	58	109			120	56	162	98	204	140									
	3	71	128					149	79	191	121	233	162	275	204					
	4	85	152					136	54	177	96	219	138	261	180	303	222			
	5	111	196							151	53	193	95	235	136	276	178	339	241	
SR75 *	1	89	172	168	63	244	138	319	214											
	2	118	226			215	85	291	160	366	235									
	3	133	249					275	137	351	212	426	288	502	363					
	4	162	303					247	83	322	158	398	234	473	309	549	385			
	5	205	380							279	81	354	157	430	232	505	308	618	421	
SR85 *	1	143	242	238	109	349	219	460	330											
	2	176	298			316	163	427	274	537	384									
	3	215	361					387	211	498	322	609	432	720	543					
	4	248	417					354	155	465	265	576	376	687	487	797	633			
	5	321	536							392	146	503	257	614	368	725	478	891	645	
SR100 *	1	218	395	384	154	556	326	728	499											
	2	288	521			485	199	658	372	830	544									
	3	318	564					628	329	801	502	973	674	1146	847					
	4	389	691					558	203	730	375	903	548	1075	720	1248	893			
	5	489	860							630	206	802	378	975	551	1147	723	1406	982	
SR115	1	363	658	650	270	935	555	1220	840											
	2	449	835			848	378	1133	663	1419	949									
	3	538	957					1044	541	1329	827	1615	1112	1900	1397					
	4	625	1133					958	365	1243	650	1528	935	1813	1220	2098	1505			
	5	800	1432							1067	352	1352	637	1638	922	1923	1207	2350	1635	
SR125	1	470	877	850	328	1224	703	1599	1077											
	2	560	1040			1135	400	1400	840	2000	1883									
	3	718	1313					1351	640	1725	1015	2099	1389	2474	1763					
	4	808	1477					1261	477	1636	851	2010	1226	2384	1600	2758	1974			
	5	1055	1913							1388	415	1762	789	2136	1164	2511	1538	3072	2099	
SR140	1	726	1346	1240	508	1742	1010	2244	1512											
	2	815	1523			1642	821	2144	1323	2646	1825									
	3	1036	1958					1910	856	2412	1358	2914	1861	3408	2355					
	4	1134	2126					1810	668	2312	1170	2814	1672	3308	2166	3810	2668			
	5	1453	2728							1979	515	2481	1017	2975	1511	3477	2013	4233	2769	
SR160	1	735	1159	2036	1585	2741	2290													
	2	1053	1664			2405	1532	3085	2438											
	3	1266	1991			2184	1405	2863	2084	3552	2773									
	4	1637	2584					2465	1456	3153	2463	3859	2850							
	5	1788	2823							2985	1896	3691	2603	4405	3317					
	6	2372	3744								3080	1620	3795	2335	4474	3014	5528	4069		
SR180	1	903	1487	2540	1921	3239	2620													
	2	1416	2230			2691	1823	4089	3222											
	3	1611	2602			2487	1434	3885	2832	5275	4222									
	4	2319	3664					3133	1735	4523	3124	5222	3824							
	5	2319	3717							4523	3036	5222	3735	5921	4434					
	6	3222	5151								4266	2248	4965	2947	6364	4346	7762	5744		
SR200	1	1496	2222	3638	2895	4954	4211													
	2	2098	3124			4264	3211	5531	4477											
	3	2549	3788			3812	2556	5080	3823	6338	5081									
	4	2992	4620					4549	2885	5807	4144	7132	5468							
	5	3593	5346							5196	3418	6521	4742	7837	6058					
	6	4487	6842								5539	3150	6854	4465	8122	5732	10066	7677		
SR230	1	3443	5895	4124	1522	5682	3080	8789	6187											
	2	4124	7072			4956	1823	8063	4930											
	3	4815	8258					7328	3682	10444	6797									
	4	5505	9435					6603	2425	9718	5541	11276	7098							
	5	6196	10612					5868	1177	8984	4293	10541	5850	12090	7399					
	6	6877	11789							8258	3036	9815	4594	11364	6142	14480	9258	17586	12364	
SR270	1	4478	7001	8096	5530	11308	8742	14548	11982											
	2	5372	8399	7141	4061	10353	7273	13627	10513											
	3	6266	9798	5229	2592	9397	5804	12637	9044	15877	12284									
	4	7169	11196			8450	4344	11690	7583	14930	10823	18141	14036							
	5	8063	12595					10734	6114	13974	9354	17185	12566	20397	18478					
	6	8957	13993					9778	4645	13018	7885	16230	11097	19441	14308					
	7	9851	15400					8823	3216	12062	6416	15275	9628	18486	12839	21717	16071			
	8	10745	16799					7867	1707	11107	4947	14319	8159	17530	11370	20762	14602	25593	19434	
SR330	1	7824	12143	12046	7452	16117	11524	24260	19666											
	2	9382	14577	10382	4868	14453	8939	22596	17082											
	3	10948	17002	8718	2292	12789	6364	20932	14506	29075	22649									
	4	12515	19436			11134	3779	19277	11922	27420	20065	31491	24136							
	5	14082	21861					17613	9346	25756	17489	29827	21560	33898	25632					
	6	15639	24295					15949	6762	24092	14905	28163	18976	32234	23047					
	7	17206	26720					14294	4186	22437	12329	26508	16400	30579	20472	38713	28606			
	8	18772	29154							20773	9745	24844	13816	28915	17887	37049	26021	45192	34164	

\* Valid also for stainless steel actuator.

