



JOB NAME:	CONTRACTOR:
JOB LOCATION:	APPROVAL:
ENGINEER:	CONTRACTOR P.O.:
APPROVAL:	REPRESENTATIVE:

E700E

700E GROOVED END EPOXY-COATED DUCTILE IRON BODY, EPDM SEATS WITH VALBIA ELECTRIC ACTUATOR

SIZES 2" TO 10"

E700B

700B GROOVED END EPOXY-COATED DUCTILE IRON BODY, BUNA SEATS WITH VALBIA ELECTRIC ACTUATOR

SIZES 2" TO 10"

*001	12V AC/DC	*002	24V AC/DC	*003	100-240V AC
01	BATTERY BACKUP	*02*	POSITIONER	*04*	BATTERY BACKUP W POSITIONER

SPECIFICATIONS

The Bonomi E700E series electric actuated package features an ISO 5211 direct mount epoxy coated, ductile iron, EPDM coated disc, grooved end ball valve. The E700B electric package is the same except utilizing a BUNA-N coated disc. The Valbia electric VB series actuator fits directly over the 700E/700B series square stem and ISO 5211 pad. The actuator also is standardly furnished with dual voltages, two extra limit switches, torque limiter, extended manual override, 75% duty cycle motor, in a IP 67, NEMA 4, 4X techno polymer housing.

ACTUATOR FEATURES

- NEMA 4, 4X Housing
- 12V/24V AC/DC and 100-240V AC Models Available
- ISO 5211 dual patterns
- VB015 -12/24V AC - 50% Duty Cycle
- VB030-VB060 - 12/24V DC and 100-240V AC - 75% Duty Cycle
- High-Strength, Impact Resistant IP67 Technopolymer Housing
- Temperature Range -4°F to 131°F
- PG11 Electrical Connection/Optional 1/2" conduit connection

VALVE FEATURES

- Grooved End Epoxy-coated Ductile Iron body
- Sizes 2" to 10"
- ISO 5211 Direct Mount/Square Stem
- Epoxy coated Ductile Iron Wafer body
- EPDM seat (-30°F TO 250°F)
- BUNA seat (10°F TO 250°F)
- Face to face MSS-SP-67
- Ends meet ANSI AWWA C606
- Temperature Range: -4°F to 212°F

PRESSURE - TEMPERATURE CHART FOR SERIES 700E/700B

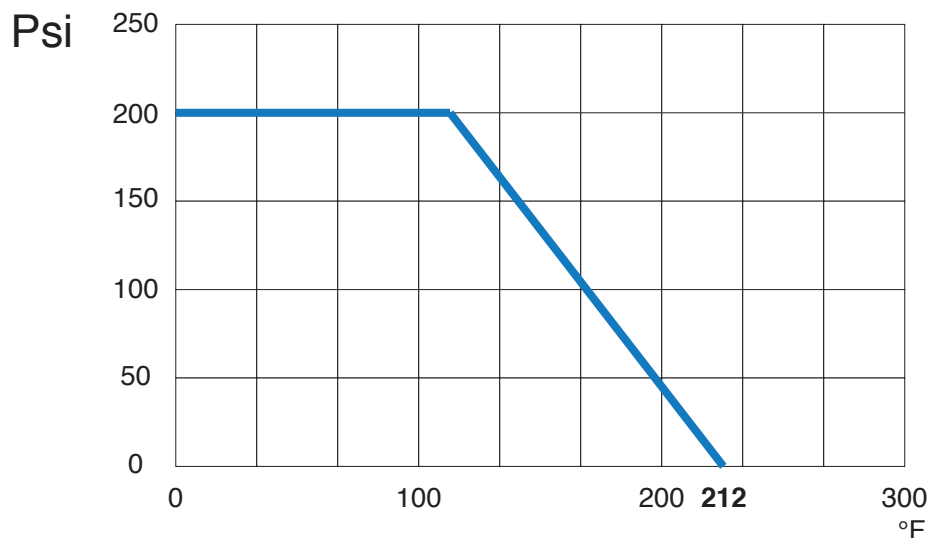

BILL OF MATERIALS

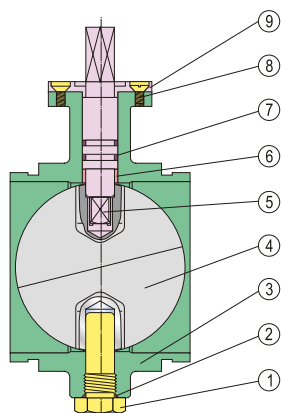

N POS	PART NAME	MATERIAL	N PCS
1	LOWER SHAFT	410 STAINLESS STEEL	1
2	SEAT	EPDM (-30°F TO 250°F) BUNA (10°F TO 250°F)	1
3	BODY	CAST IRON / DUCTILE IRON	1
4	DISC	DUCTILE IRON + NBR/EPDM	1
5	UPPER SHAFT	410 STAINLESS STEEL	1
6	BUSHING	P.T.F.E.	1
7	O-RING	EPDM (-30°F TO 250°F) BUNA (10°F TO 250°F)	1
8	SCREW	CARBON STEEL ZINC PLATED	1
9	COVER	CARBON STEEL NICKEL PLATED	1

DIMENSIONS

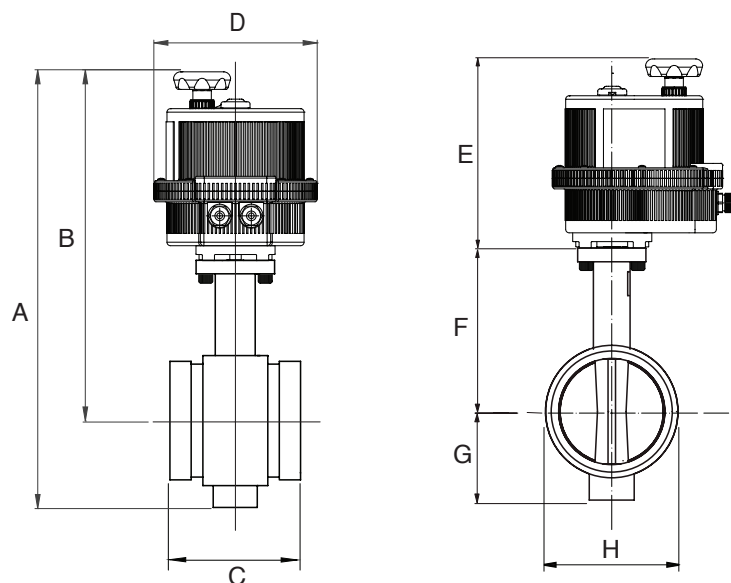

Size	2"	2-1/2"	3"	4"	5"	6"	8"	10"
A	14.56	15.03	16.78	18.78	20.14	21.18	23.15	26.35
B	12.08	12.34	13.63	15.08	15.89	16.34	17.27	19.03
C	3.24	3.81	3.81	4.55	5.81	5.81	5.25	6.25
D	6.18	6.18	7.28	8.31	8.31	8.31	8.74	8.74
E	7.40	7.40	8.46	9.14	9.14	9.14	9.19	9.19
F	4.68	4.94	5.17	5.94	6.75	7.20	8.08	9.84
G	2.48	2.69	3.15	3.70	4.25	4.84	5.88	7.32
H	2.37	2.87	3.50	4.50	4.50	6.62	8.62	10.7
Act.	VB030	VB030	VB060	VB110	VB190	VB190	VB270	VB350

ON/OFF WIRING DIAGRAM - VB030 -VB190

12V AC/DC, 24V AC/DC & 100-240VAC

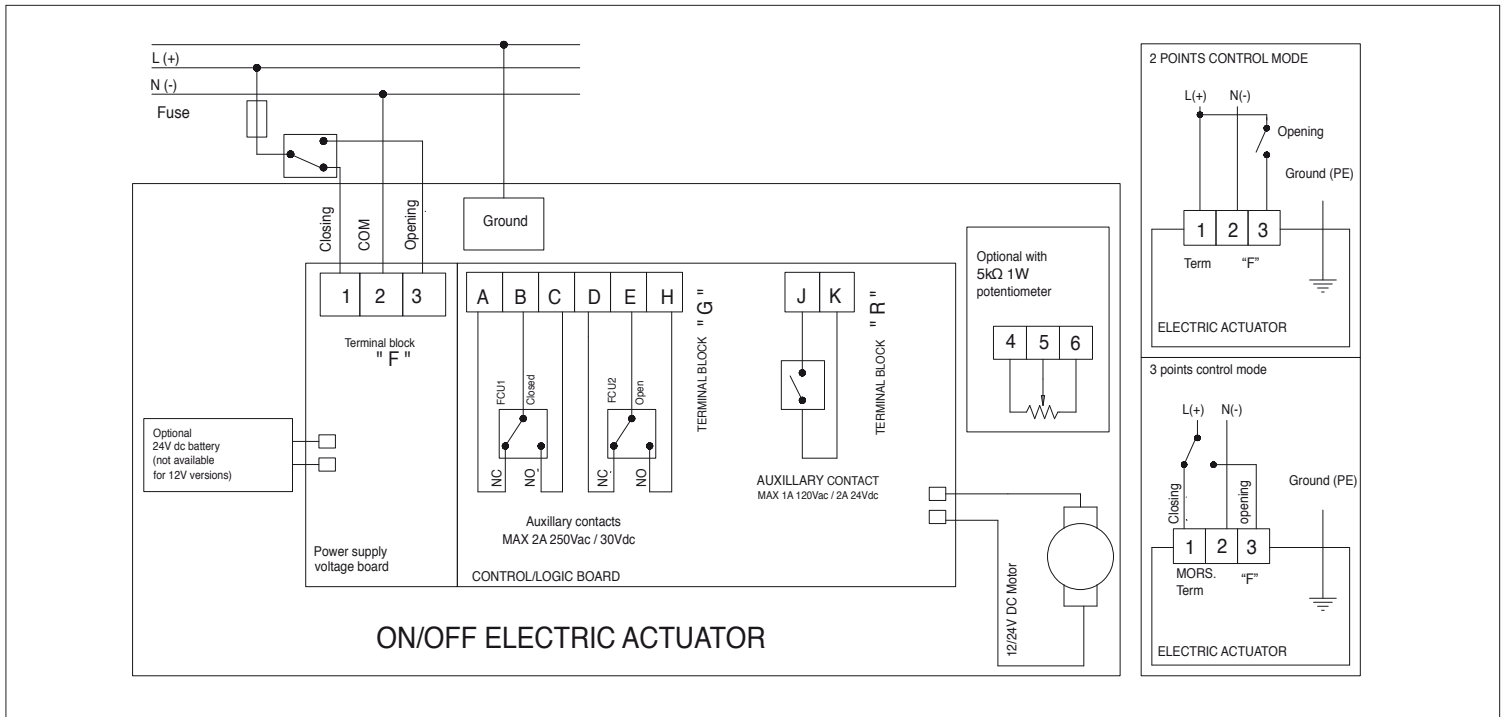

POSITIONER WIRING DIAGRAM - VB030 -VB190

12V AC/DC, 24V AC/DC & 100-240VAC

