



JOB NAME:	CONTRACTOR:
JOB LOCATION:	APPROVAL:
ENGINEER:	CONTRACTOR P.O.:
APPROVAL:	REPRESENTATIVE:

## M8E1300-00\*

**1300 2-WAY, 3-PIECE DIRECT MOUNT STAINLESS STEEL, STAINLESS STEEL PORT INSTRUMENTATION BALL WITH VALBIA METAL ELECTRIC ACTUATOR**

**SIZES 1/4" TO 3/4"**

*001	12V AC/DC	*002	24V AC/DC	*003	100-240V AC
*01*	BATTERY BACKUP	*02*	POSITIONER	*04*	BATTERY BACKUP W POSITIONER

### SPECIFICATIONS

The Bonomi M8E1300 series electric actuated package features a stainless steel, 2000psi 3-piece, ISO 5211 direct mount ball valve with compression ends. The valve also has TFM-1600 seats, and a multiple stem packing design for high cycle applications.

The Valbia electric VBM metal housing actuator fits directly over the 1300 series ball valve with square stem and ISO 5211 pad. The actuator also is standardly furnished with dual voltages, two extra limit switches, torque limiter, manual override, a dome position indicator, 1/2" conduit connections, 75% duty cycle motor, contained in a NEMA 4 cast aluminum powder coated housing.

### ACTUATOR FEATURES

- Dual Voltages
- 24V AC/DC and 100-240V AC Models Available
- ISO 5211 dual patterns
- 75% Duty Cycle
- Anti-condensation heater, (when red wire is connected to power)
- High-Strength, Die Cast Aluminum Powder Coated Housing
- Temperature Range -4°F to 131°F
- NEMA 4 Housing
- Two Auxiliary Switches Standard
- Torque limiter standard
- 1/2" conduit connection

### VALVE FEATURES

- 3-Pc. Stainless Steel Port Instrumentation Ball
- Standard port, sizes 1/4" to 3/4"
- Working pressure to 2000 psi
- Temperature range -4°F to 450°F
- ISO 5211 mounting pad with square stem
- TFM1600 seats
- P.T.F.E. packing and seals
- Extremely high cycle life
- Compression ends with heat treated ferrules

### PRESSURE - TEMPERATURE CHART FOR SERIES 1300

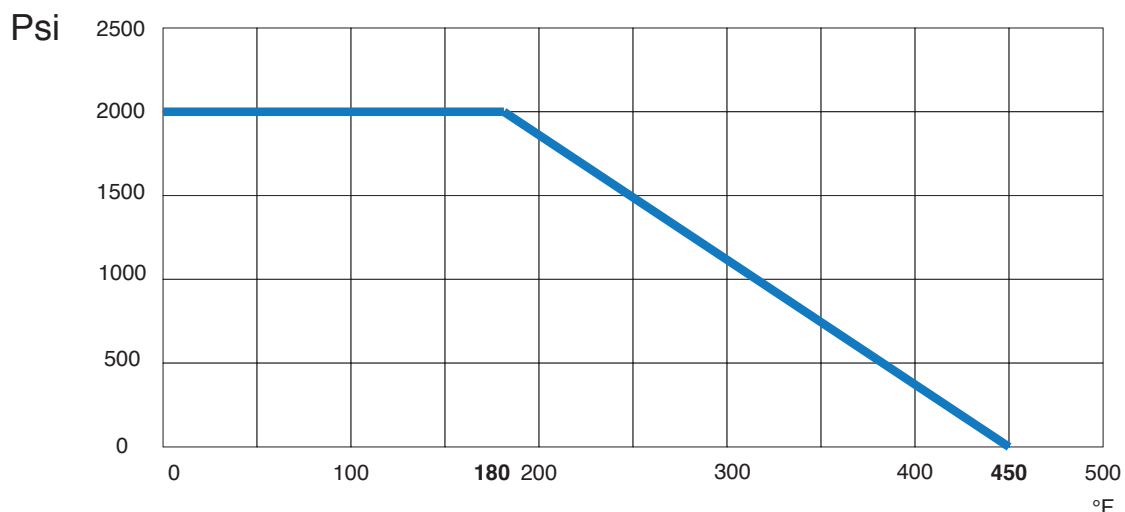

## BILL OF MATERIALS FOR 1300

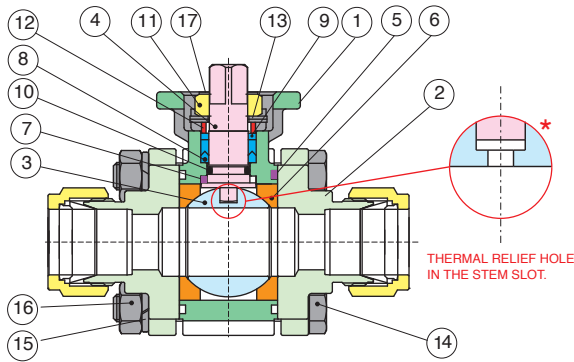

N POS	PART NAME	MATERIAL	N PCS
1	BODY	CF8M	1
2	END CAP	CF8M	2
3	BALL	SS 316	1
4	STEM	SS 316	1
5	PACKING	P.T.F.E.	2
6	SEAT	TFM1600	2
7	STEM SEAL	P.T.F.E.	1
8	V-RING PACKING	P.T.F.E.	1 Set
9	BUSHING	50% SS - 50% P.T.F.E.	1

N POS	PART NAME	MATERIAL	N PCS
10	O-RING	FKM (Viton®)	1
11	STEM NUT	SS304	1
12	GLAND	SS304	1
13	BELLEVILLE WASHER	SS304	2
14	BOLT	SS304	4
15	WASHER	SS304	4
16	BOLT NUT	SS304	4
17	LOCK SADDLE	SS304	1

## DIMENSIONS

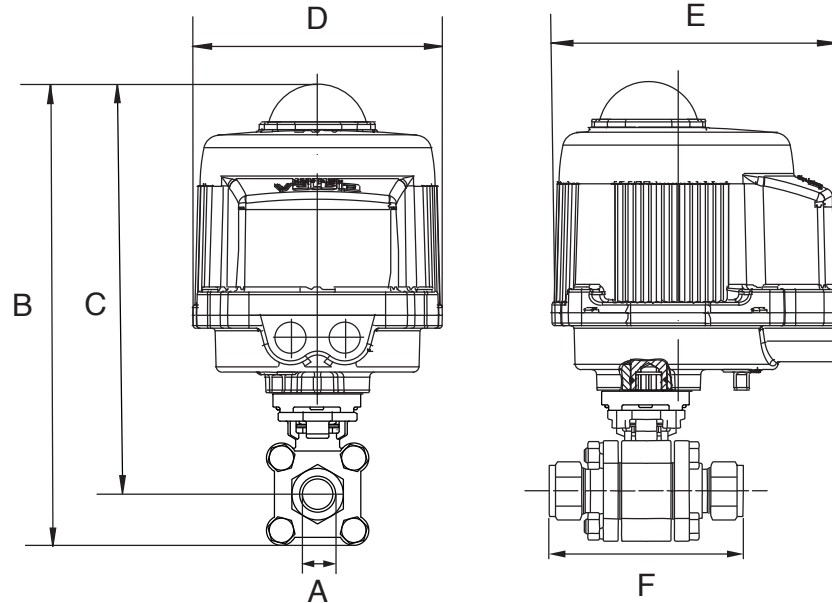

Size	1/4"	3/8"	1/2"	3/4"
A	0.18	0.25	0.37	0.63
B	11.35	11.35	11.35	11.35
C	9.43	9.43	9.43	9.43
D	6.34	6.34	6.34	6.34
E	7.36	7.36	7.36	7.36
F	3.74	3.79	4.02	4.02
Act.	VB030M	VB030M	VB030M	VB030M

## ON/OFF WIRING DIAGRAM - VB030M

12V AC/DC, 24V AC/DC & 100-240VAC

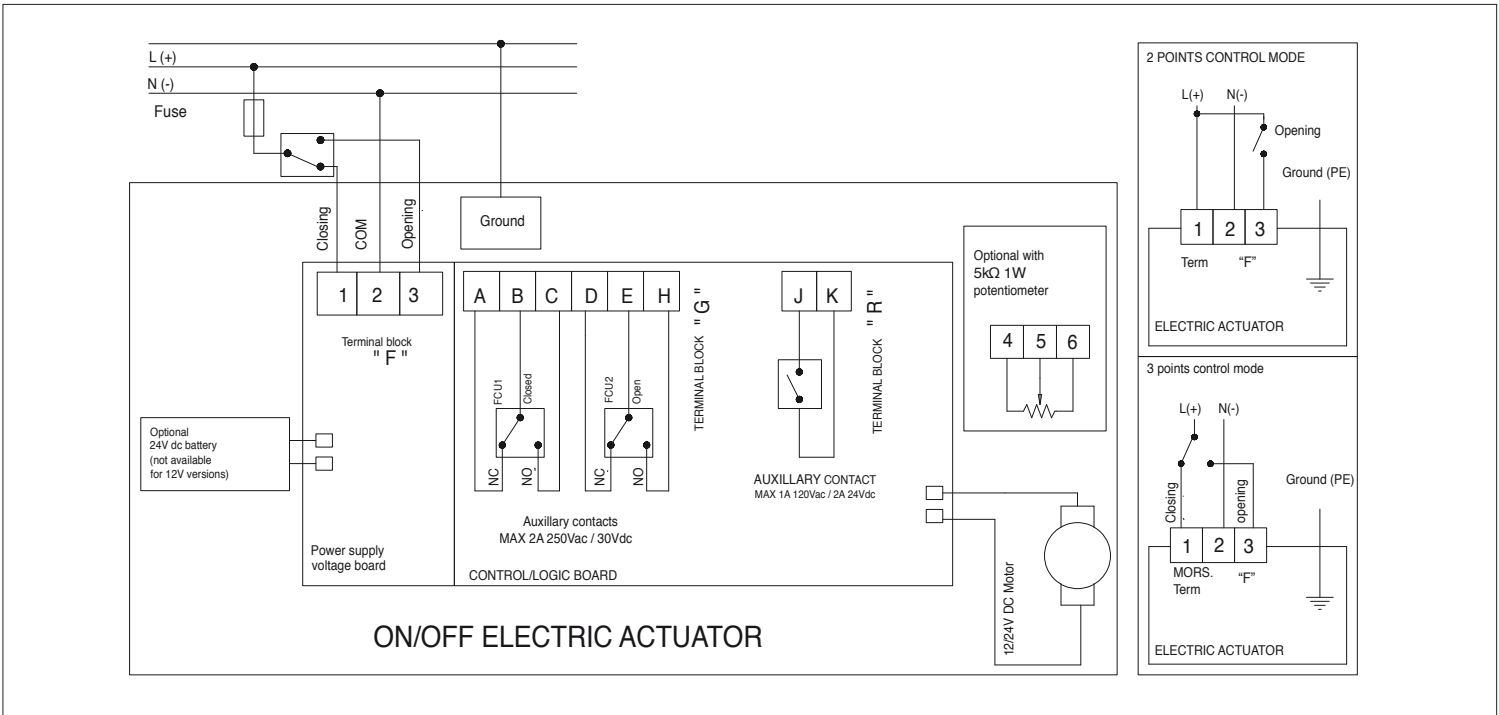

## POSITIONER WIRING DIAGRAM - VB030M

12V AC/DC, 24V AC/DC & 100-240VAC

