

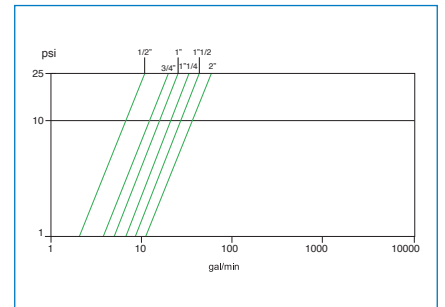

SERIES S250 CHECK VALVE

High capacity, in-line spring loaded, stainless check valve, FNPT threaded.
Pressure rating: size 1/2"-2", 250 WOG.

- FKM (Viton®) seat for bubble tight shutoff, spring loaded for fast seating action.
- Low cracking pressure at 1/2 psi.
- Flow profile designed to minimize head loss.
- Temperature range: -4°F to +302°F.
- Corrosion resistant.
- AISI 316 cold formed stainless steel.
- ANSI B1.20.1 connections.

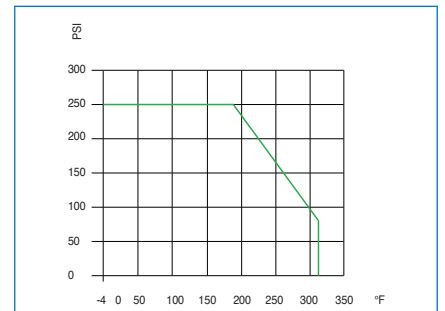
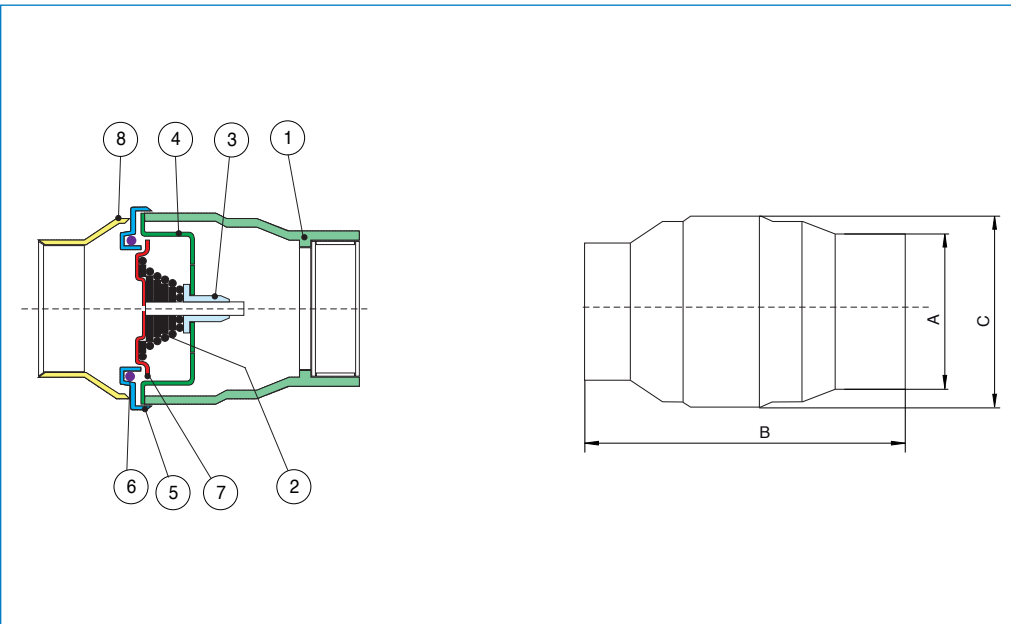

N POS	PART NAME	MATERIAL	N PCS
1	BODY	AISI 316	1
2	SPRING	AISI 316	1
3	GUIDE BUSH	P.T.F.E	1
4	DISC GUIDE	AISI 316	1
5	SEAL RING HOUSING	AISI 316	1
6	GASKET	FKM (Viton®)	1
7	FLOW CONTROL DISC	AISI 316	1
8	END CAP	AISI 316	1

SIZE	A	B	C	Cv	psi	Weight Lbs
1/2"	0.98	2.17	1.26	9.13	250	0.21
3/4"	1.18	2.63	1.73	15.95	250	0.28
1"	1.41	3.27	2.09	21.62	250	0.42
1 1/4"	1.77	3.82	2.44	35.84	250	0.62
1 1/2"	2.00	4.53	3.07	47.40	250	0.86
2"	2.48	4.74	3.50	64.74	250	1.55