

SERIES S800 STAINLESS STEEL IN-LINE CHECK VALVE



High capacity, size 1/4"-2" 800 WOG.

- Soft P.T.F.E seat for bubble tight shutoff, spring loaded for fast seating action.
- Low cracking pressure 1/2 psi.
- Flow profile designed to minimize head loss.
- Perfect seating both at high and low pressure, wide temperature range: +10°F to 450°F.
- Corrosion resistant-excellent for use on chemicals.
- ASTM A351-CF8M investment casting.
- Connection: FNPT x FNPT.
- 125WSP saturated steam.
- ANSI B1.20.1 threads.
- Dual guided stem & disc.

S800FV: SS foot valve design.

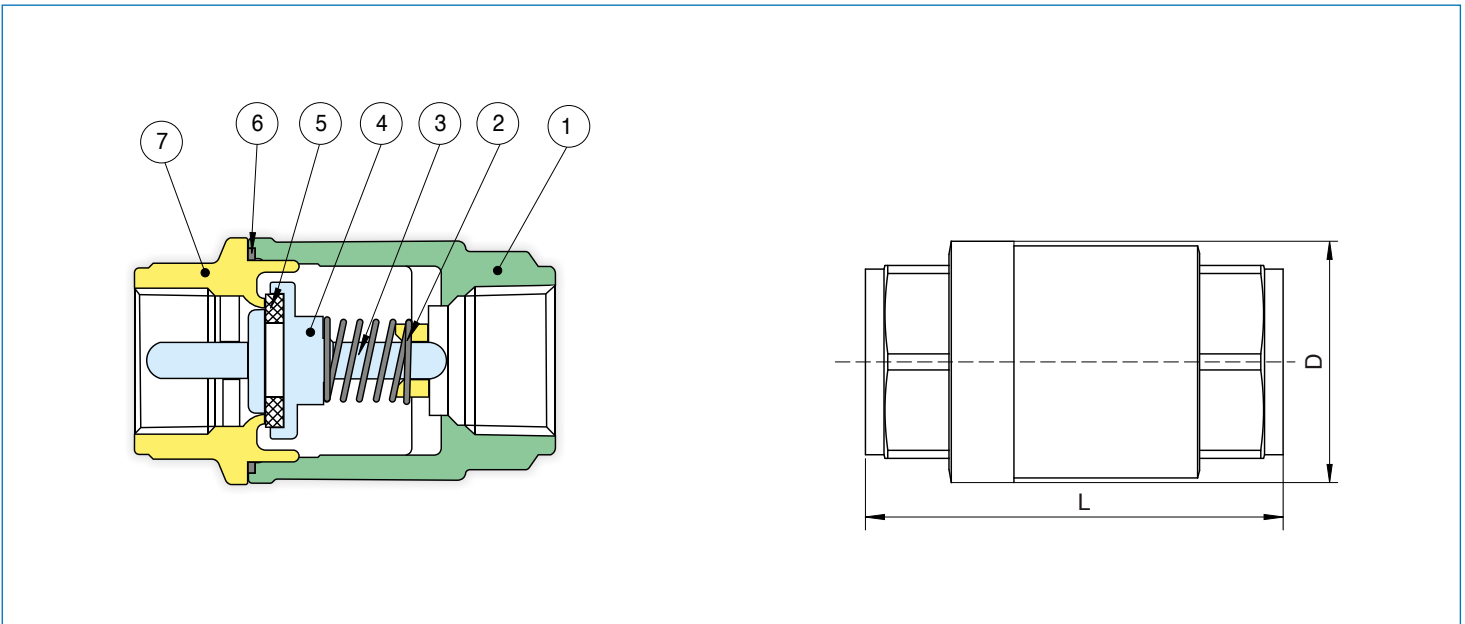

N Pos	PART NAME	MATERIAL	N PCS
1	BODY	ASTM A351-CF8M	1
2	SPRING	SS316	1
3	CENTER GUIDE	ASTM A351-CF8M	1
4	DISC	ASTM A351-CF8M	1
5	SEAT	P.T.F.E	1
6	GASKET	P.T.F.E	1
7	END CAP	ASTM A351-CF8M	1

SIZE	D	L	CV	psi	Lbs
1/4"	1.35	2.31	3.50	800	0.42
3/8"	1.35	2.31	3.50	800	0.42
1/2"	1.35	2.31	5.20	800	0.40
3/4"	1.81	2.87	10.00	800	0.85
1"	2.13	3.50	15.00	800	1.30
1 1/4"	2.46	4.18	24.50	800	2.50
1 1/2"	2.88	4.93	35.20	800	3.40
2"	3.56	6.00	52.00	800	6.00